

# Tahoe

## Installation and Operating Manual



### INTRODUCTION

The Tahoe is a single pump for industrial and warewash applications. Setup is handled via potentiometers located on the front of the unit under the cover. The Tahoe can dose based on time, speed, time and speed, or pushing the rocker switch. It doses recharge upon receipt of a signal and initial charge after the signal has been present for 20 seconds. It runs continuously at the set speed for rinse applications. It has a modular design so units can fit together for multiple product applications, and also has side knockouts for conduit connections. For manually activated dosing applications such as pot & pan, the Tahoe Remote is available with a remote push button dose trigger. For encapsulated product, the Tahoe is available with a solenoid.

### PREFACE

Material in this manual is subject to change without notice. Special circumstances involving important design, operation, or application information will be released via Equipment Technical Bulletins. Every effort has been made to ensure this information is accurate, but no guarantee is made as to the accuracy or completeness of this document.

© Beta Technology, Inc., 2002

### SPECIFICATIONS

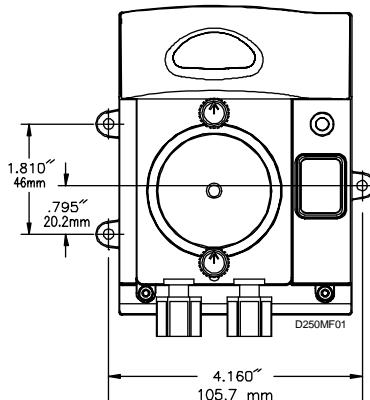

Figure 1. Tahoe Dimensions

#### Enclosure

Molded ABS plastic, water-resistant, flame retardant

#### Pump

Peristaltic, self priming, self checking, 24 VDC  
Maximum Vacuum: 8in/200mm of Mercury [Hg]  
Maximum Pressure: 10psi/0.7 bar/69 kPa detergent,  
30psi/2.1 bar/200kPa rinse

Detergent Flow Rate: 110ml/min nominal, not to run more than 15 out of 30 minutes

Rinse Flow Rate: 16ml/min nominal, unlimited continuous run with rinse tube

#### Ambient Temperature

104°F (40°C) maximum

#### Potentiometers

Speed: 1-100%

Recharge: 0-20sec/continuous

Initial Charge: 0-190 seconds

#### Rocker Switch

Up: Init. Charge/Prime

Middle: Enable pump

Down: Disable pump

#### Electrical

Input voltage 100-120 VAC 50/60 Hz 0.2 amp

Input voltage 200-240 VAC 50/60 Hz 0.1 amp

Alternate initial charge option voltage 24 VAC (+/-10%)

50/60 Hz 0.5 amp (use transformer 066135)

Please note that 230 VAC Tahoes do not have 100-120 VAC input wires. Tahoe Remotes and Tahoe pot-and-pan units only accept 100-120 VAC inputs.



*Please note that the Tahoe still has high voltage inside when disabled, and must only be serviced by qualified personnel.*

*To comply with the European Union EN61010-1, the input power source must go through an on/off switch or circuit breaker, such as that on the dishwasher. This must be marked as the disconnecting device for the equipment.*

#### Regulatory

CE, NSF, CSA, NRTL/C

### INSTALLATION AND SETUP

The Tahoe installation chart shows potentiometer settings and power sources for typical warewash applications. Most applications utilize a single power input for initial charge and recharge, but exceptions with a separate power input for initial charge are noted on the chart.

#### Alternate Initial Charge (Europe)

This wiring configuration uses the Tahoe power input cable to trigger recharge from the rinse arm, and a fill valve signal to trigger initial charge. The fill valve signal needs to go through a transformer so it is 24 VAC. This procedure must only be performed by qualified personnel.

- Ensure no wires are live. Remove top cover by inserting screwdriver under right side of cover and gently prying off. Be careful not to damage unit. Remove screws.
- Bring the 24 VAC fill valve input from the transformer through the knockout on the bottom of the Tahoe.

- Connect to the two quick disconnects in the Tahoe enclosure.
- Route wires per the diagram in the back of this manual.
- When replacing screws, insert into holes and turn counterclockwise until they click/seat into the threads prior to screwing in clockwise.

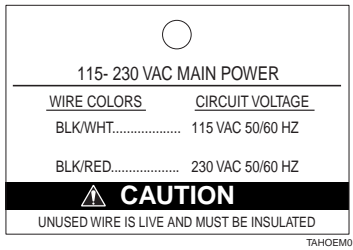

Figure 2. Input Voltage Cable label



Dual supply voltage Tahoe's have a three wire cable which accepts the label shown in Figure 2 on either 115 or 230 VAC voltage inputs. The unused wire must be insulated.

Single supply voltage units have a brown and a blue wire for 230 VAC input.



For installations where the local law requires, the power supply cable must be housed in an impact-proof conduit to prevent severing of the cable. Please refer to your local authorities for details.

#### Prime/Push-Button Initial Charge

- Pushing the rocker switch up will activate initial charge if power is present. A second push will stop the dose.
- If initial charge = 0, the pump will operate as long as the switch is held up.

#### Remote Push Button Initial Charge

The Tahoe Remote is for pot and pan and other manually activated dosing applications. It comes with a plug to accept a normal power supply from the wall.

To use Remote for Initial Charge:

- Put all settings to "0" before connecting to power.
- Set recharge to "0", speed to 100%, and initial charge to desired dose size.
- Tahoe will dose initial charge amount whenever you push the Remote button.
- Note that it does not wait 20 seconds to dose when the button is pushed, but begins the dose immediately.

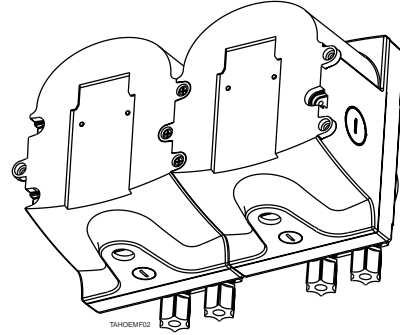

Figure 3. Rear view of two Tahoe units, interlocked with #6 x 1/2" (12mm) self-tapping screws

#### Pot-and-Pan Sink Applications

The Tahoe solenoid has only low voltage in the dispenser, so it can be safely installed over a sink. It is intended for use with an encapsulated product and bowl unit such as W-6000.

1. Mount Tahoe unit near the sink, plug it in and attach tubing.
2. Set the speed to 100%. The solenoid will turn on and off, making a clicking noise, if the speed is not set to 100%.
3. Set the recharge to 0.
4. Set initial charge for the desired dose size.

The Tahoe is now ready for operation. It will dose the initial charge amount whenever the switch on the front panel is pressed upward.

# TAHOE INSTALLATION CHART

Application	Chemical	Injection Point	Power	Alternate Initial Charge	Speed 	Recharge 	Initial Charge 	Figure
Door	Liquid Detergent	Wash Tank	Rinse Solenoid	N/A	100%	0-20 sec	0-190 sec	4 & 5
Door	Liquid Detergent	Wash Tank	Rinse Solenoid	Fill Valve	100%	0-20 sec	0-190 sec	
Door	Liquid Rinse	Booster	Wash Pump	N/A	100%	0-20 sec	0 sec	4
Door	Liquid Rinse	Rinse Line	Rinse Solenoid	N/A	1%-100%	Continuous	0 sec	5
Conveyer	Liquid Detergent	Wash Tank	Rinse Solenoid	Fill Valve	100%	0-20 sec	0-190 sec	6
Conveyer	Liquid Rinse	Rinse Line	Rinse Solenoid	N/A	1%-100%	Continuous	0 sec	6
Manual Dose	Various Liquids	Various	Plug	N/A	1%-100%	0	0-190 sec	
Sink/Solenoid	Dry/Solid Chemical		Wall-mount 115VAC Transformer	N/A	100%	0	0-190 sec	

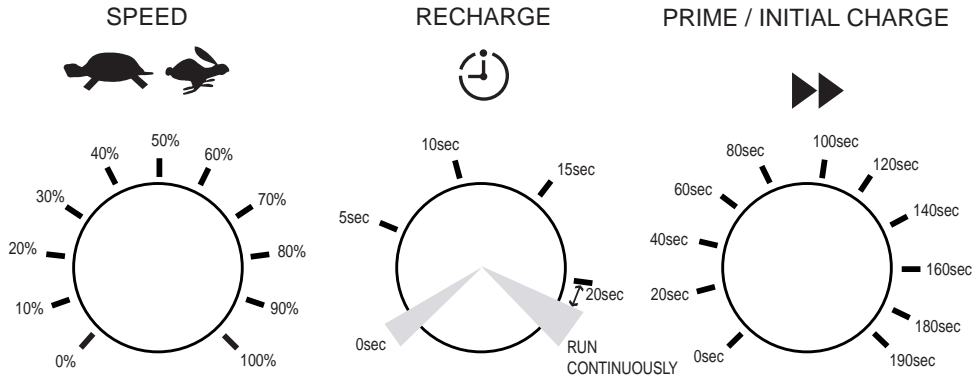

TAHOEM03



Turn potentiometers gently; they are fragile.

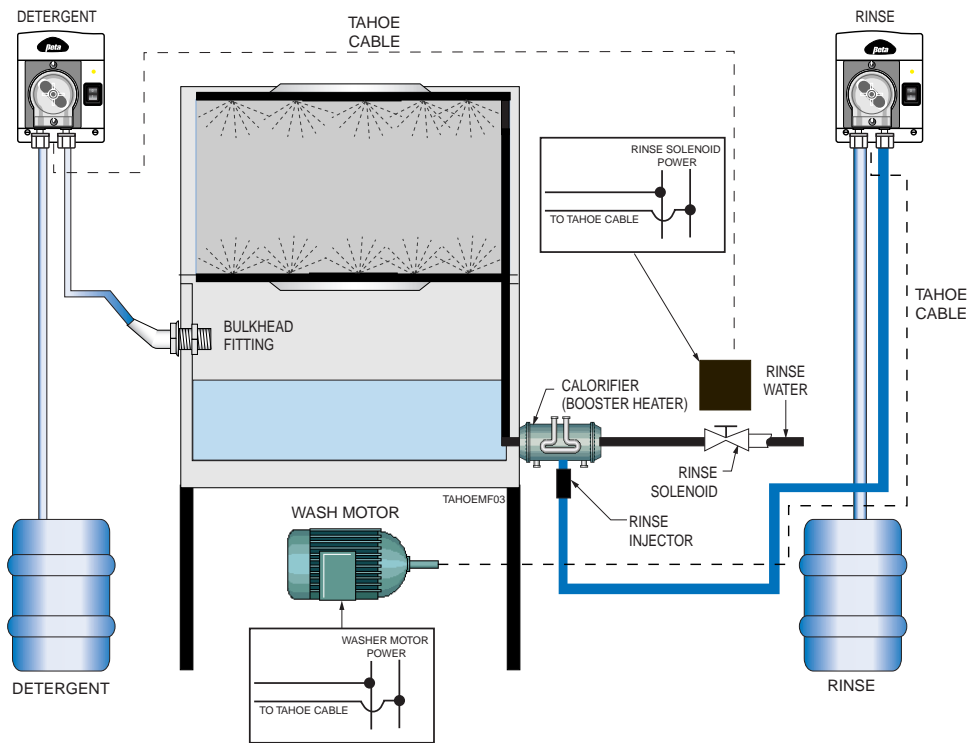

Figure 4. Tahoe with Door machine

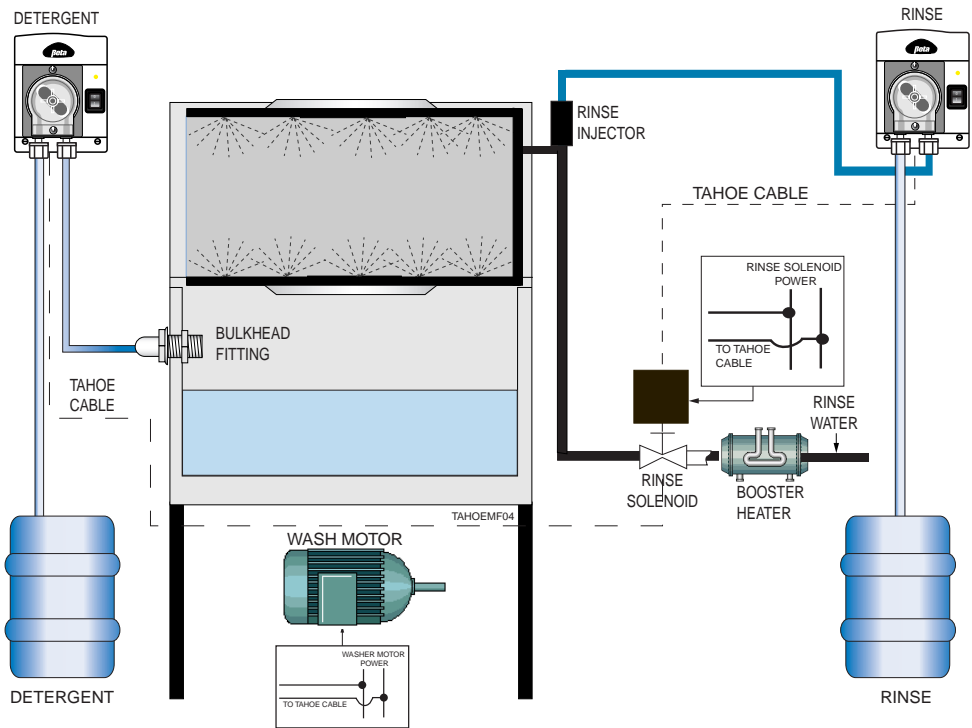

Figure 5. Tahoe with door machine-Rinse injection into pressurized rinse line

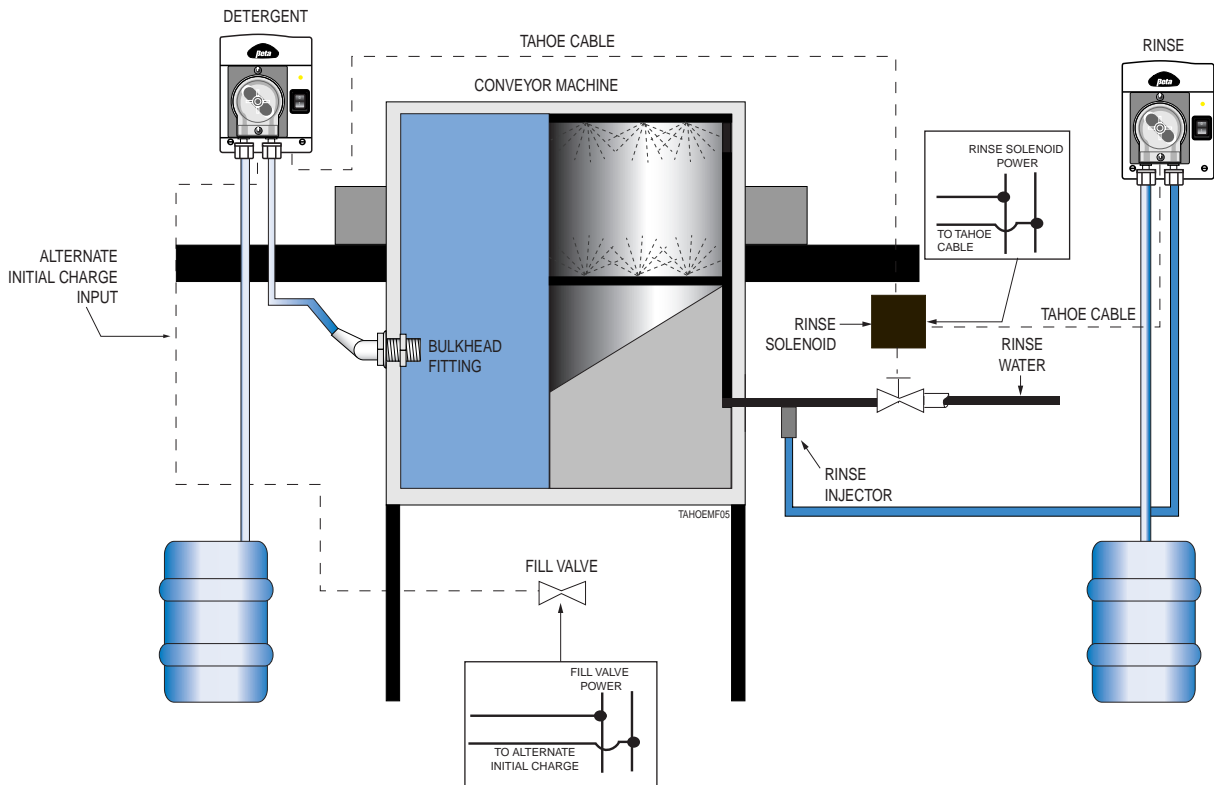

Figure 6. Conveyor machine with alternate initial charge

## MAINTENANCE

### REPLACING PUMP CARTRIDGES

#### To Remove

1. Disable pump (power remains on).
2. Remove the cartridge from the motor housing by twisting the snap pins.

#### To Install

1. Align and engage the pump drive spline with the motor gear by rotating the roller assembly.
2. Turn the snap pins so that the arrow is pointed up. Then push in until you hear a distinct click.

#### Replacing Pump Squeeze Tubing



To protect against pressurized spray, wrap a rag around the connections when replacing tubes.

1. Remove the cartridge as described above.
2. Remove the small screw at the bottom of the rear cover and lift the cover from the cartridge.
3. Pull the adapter fittings back until they clear the cartridge.
4. Pull the roller assembly back to release the pump squeeze tubing.
5. Cut the tie wraps holding the pump squeeze tubing to the adapter fitting and pull the tubing from the fittings.

6. Replace the pump squeeze tubing, making certain to use the proper size tube.
7. Push the adapters to the ends of the tubing and secure with tie wraps. Make certain that the "buckles" of the tie wraps are both facing the same direction. This will keep the tube from twisting in the cartridge.
8. When using Flex, coat the inside of the cartridge with a liberal amount of Silicon 111 lubricant.
9. Press the two adapter fittings into the cartridge so that the tie wrap "buckles" face toward the center of the pump. Remember, the tube must not be twisted during the assembly.



Power remains on when pump is disabled.



Pump interior should only be serviced by qualified personnel.

#### Servicing Interior Parts

To access interior, slide top cover up and insert screwdriver under right side of cover. Gently pry off, taking care not to damage unit.

## ORDERING INFORMATION

### Complete Systems with Basic Installation Kits

#### Item# Part

099638	Tahoe, Detergent (Norprene standard), 115/230 VAC input
087298	Tahoe, Rinse (Bi-wall standard), 115/230 VAC input
087299	Tahoe, Sanitizer (Norprene standard), 115/230 VAC input
068020	Tahoe, Detergent (Norprene standard), 230 VAC input
068021	Tahoe, Rinse (Flex standard), 230 VAC input
087702	Tahoe Remote, (Norprene standard), 115 VAC input
1201016	Tahoe Solenoid, (115 VAC wall-mount transformer input)

### Spare Parts

#### Item# Part

087176	Tahoe PCB
099662	Tahoe internal transformer
051351	Motor/gearbox
039550	Roller assembly
043469	Wall-mount transformer
099986	Tahoe enclosure gasket
099705	Tahoe pump gasket
099709	Tahoe cover label
039553	Norprene detergent tube kit 1/4T-1/4T
058209	Silicone detergent tube kit 1/4T-1/4T
039552	Norprene rinse tube kit 1/8T-1/8T
058550	EPDM (Nordel) detergent tube kit 1/4T -1/4T
058552	Viton detergent tube kit 1/4T-1/4T
098158	Biwall rinse tube kit 1/8T-1/8T
092962	Flex rinse tube kit 1/8T-1/8T
097683	Flex rinse tube kit 4mmT-4mmT
058207	Silicone rinse tube kit 1/8T-1/8T
058549	EPDM (Nordel) rinse tube kit 1/8T-1/8T
058551	Viton rinse tube kit 1/8T-1/8T
092850	Flex sanitizer tube 1/4T-1/4T
057203	Norprene sanitizer tube 1/4T-1/4T
058778	Norprene food grade sanitizer tube kit 1/4T 1/4T
094678	Microbore PharMed .030"-0.76mm ID tube kit 1/8T- 1/8T

# APPENDIX-SPARE PARTS

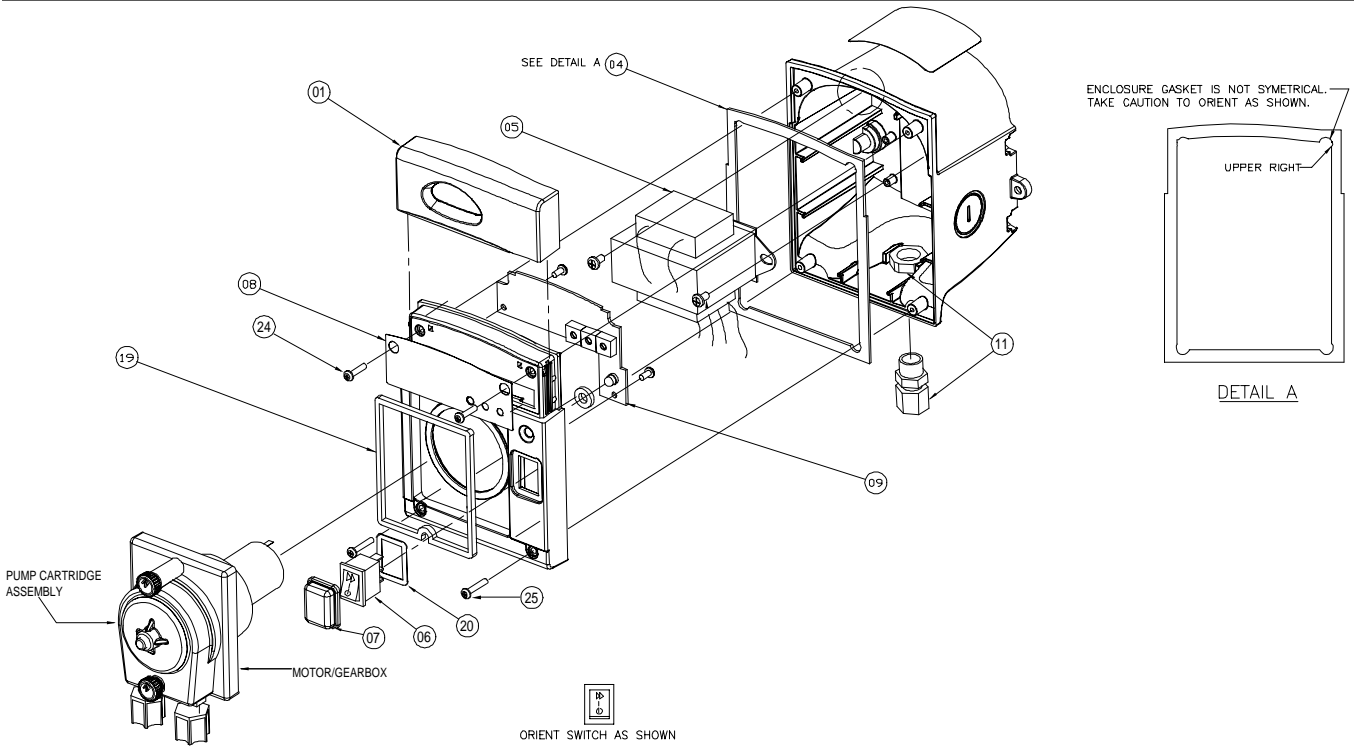

TAHOEMA01

Seq#	Item#	Description	Seq#	Item#	Description
01	099150	Tahoe enclosure door	09	087176	Tahoe PCB
04	099986	Tahoe enclosure gasket	11	032121	Strain relief
05	099662	Internal transformer	19	099705	Tahoe pump gasket
06	099153	Tahoe rocker switch	20	099693	Tahoe rocker switch gasket
07	099154	Tahoe rocker switch cover	24		SCR,T-B,PH PNH,#4X1/2,SST
08	087048	Tahoe cover label	25		SCR,T-B,PH PNH,#4X5/8,SST,BLK

# APPENDIX-WIRING

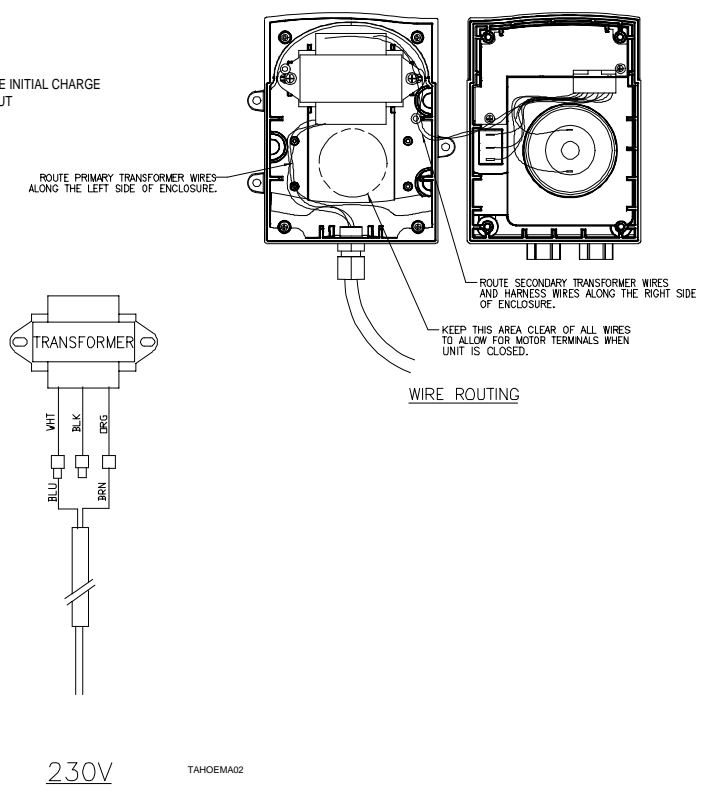
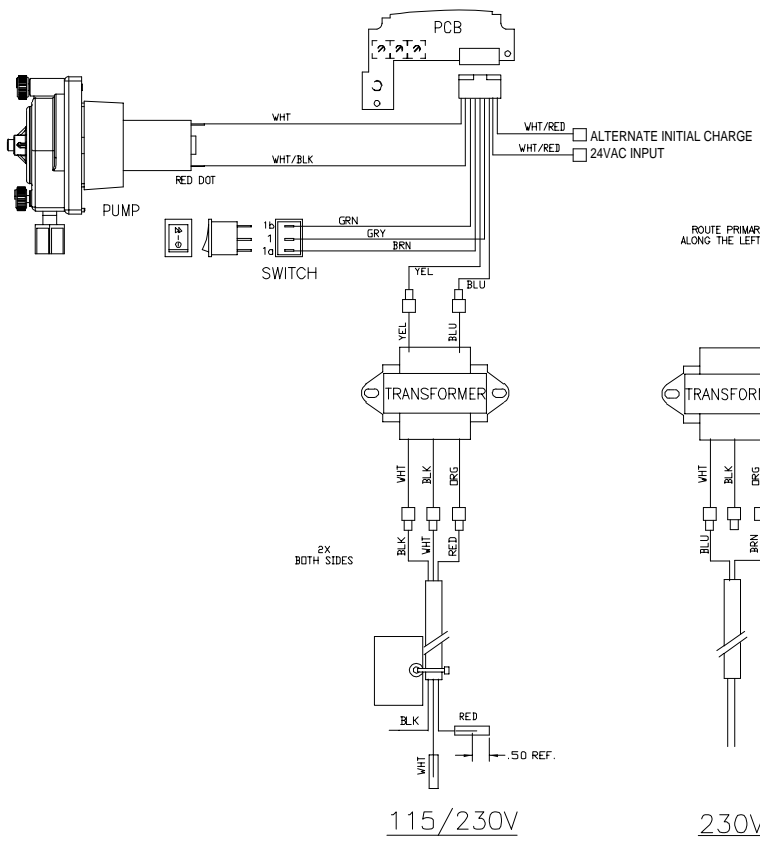



# APPENDIX-LABEL TRANSLATIONS

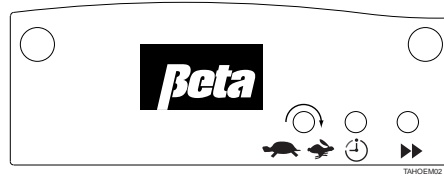

## ENGLISH

- ▶▶ Prime/Initial charge
- | On
- ⏻ Off
- 🕒 Timed dosing (recharge)
- 🚗➡ Snelheids dosering

## NEDERLANDS

- ▶▶ Voor dosering/handmatige dosering
- | Aan
- ⏻ Uit
- 🕒 Tijds dosering
- 🚗➡ Snelheids dosering

## ESPAÑOL

- ▶▶ Carga Inicial/Cebado
- | Prender
- ⏻ Apagar
- 🕒 Dosif. Temporizada
- 🚗➡ Reg. Velocidad

## DEUTSCH

- ▶▶ Antriebsmaschine/ Erstfüllung
- | An
- ⏻ Aus
- 🕒 Zeitlich kontrollierte Dosierung
- 🚗➡ Geschwindigkeitsdosierung

## PORTUGUESE

- ▶▶ Primeiro/Carga inicial
- | Ligado
- ⏻ Desligado
- 🕒 Temporização
- 🚗➡ Velocidade

## SWEDISH

- ▶▶ Tvångskörning/Grunddosering
- | Till
- ⏻ Från
- 🕒 Grund och tillsatsdosering
- 🚗➡ Varvtalsreglerad dosering



*This Manual is available in Microsoft Word. If you want to make a local translation, contact your Beta Technology, Inc. customer service representative.*



**Beta Technology**

<http://www.beta-technology.com>

913 William Leigh Drive  
Tullytown, PA. 19007

Phone 1-866-651-4323  
Fax 1-215-945-0937